

# COMe-bMT6

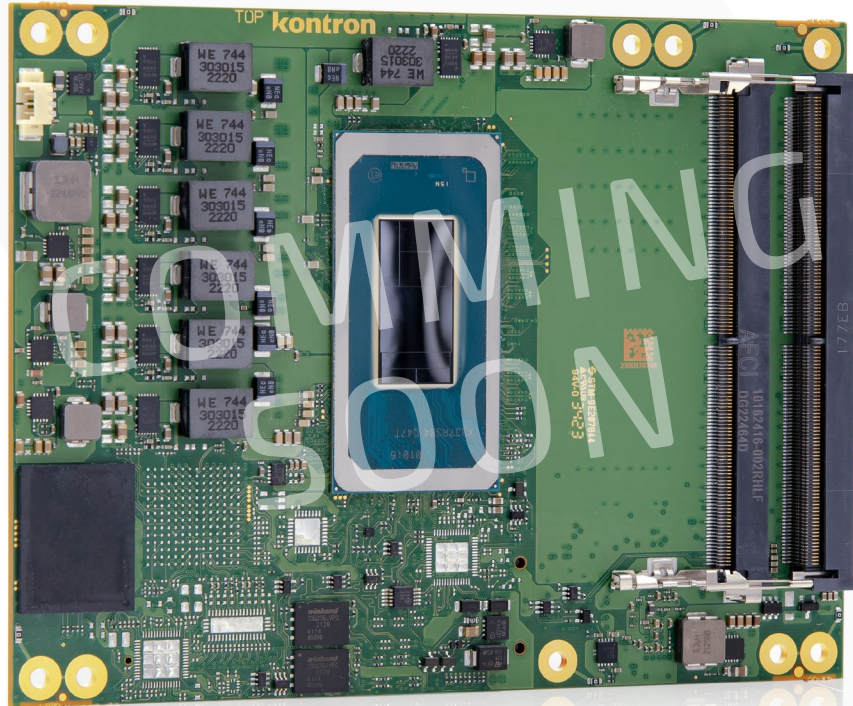

## COM Express® Basic Type 6 with Intel® Core™ Ultra Meteor Lake-H/U Series

- ▶ Intel® Arc™ Graphics architecture with up to 8 X<sup>e</sup>-Cores (128EUs)
- ▶ Integrated NPU for dedicated AI acceleration
- ▶ Up to 96 GByte DDR5 memory
- ▶ Up to 2.5 Gb Ethernet
- ▶ Optional NVMe SSDs onboard

<b>COMPLIANCE</b>	COM Express® Basic Pin-out Type 6
<b>DIMENSIONS (H X W)</b>	125 x 95 mm
<b>CPU</b>	Intel® Core™ Ultra Meteor Lake-H/U family For details see table (CPU variants) given below
<b>CHIPSET</b>	Integrated SoC
<b>MAIN MEMORY</b>	2x DDR5 S0-DIMM with up to 48 GByte per channel (non-ECC) IBEC support (dependent on used OS)
<b>GRAPHICS CONTROLLER</b>	Intel® Arc™ Graphics on H-series Intel® Graphics on U-series
<b>ETHERNET CONTROLLER</b>	Intel® I226LM
<b>ETHERNET</b>	Up to 2.5Gb Ethernet
<b>STORAGE</b>	2x SATA 6Gb/s
<b>FLASH ONBOARD</b>	Up to 2x NVMe SSD (on request)
<b>PCI EXPRESS®</b>	5x PCIe 3.0 (On request: 6x without Ethernet, up to 8x without Ethernet & SATA or alternatively 4x1+1x4 config with Ethernet & SATA) 2x4 PCIe 4.0 on PEG Lanes #0-7 1x8 PCIe 4.0 on PEG Lanes #8-15 (H-series only)
<b>DISPLAY</b>	DDI1: DP++, DDI2: DP++, DDI3: DP++, VGA: -, LVDS: Dual Channel 18/24bit
<b>USB</b>	Up to 4x USB 3.2 Gen1 (incl. USB 2.0) + 4x USB 2.0
<b>SERIAL</b>	2x serial interface (RX/TX only)
<b>AUDIO</b>	High Definition Audio interface
<b>OTHER FEATURES</b>	(G)SPI, LPC, SMB, Fast I <sup>2</sup> C, Staged Watchdog, RTC
<b>SPECIAL FEATURES</b>	Trusted Platform Module TPM 2.0 (on request)
<b>FEATURES ON REQUEST</b>	vPRO (AMT/TXT/AES Support) on dedicated SKUs, eDP instead of LVDS, VGA, USB-C, up to 8x PCIe x1 w/o Ethernet & SATA or 4x1+1x4 w/ Ethernet & SATA , up to 2x NVMe SSDs, discrete TPM
<b>POWER MANAGEMENT</b>	ACPI 6.0
<b>POWER SUPPLY</b>	8.5 V – 20 V Wide Range, Single Supply Power
<b>BIOS</b>	AMI Aptio V
<b>OPERATING SYSTEM</b>	Windows®10/11, Linux, VxWorks (project based)
<b>TEMPERATURE</b>	Commercial temperature: 0 °C to +60 °C operating, -30 °C to +85 °C non-operating
<b>HUMIDITY</b>	93 % relative Humidity at 40 °C, non-condensing (according to IEC 60068-2-78)

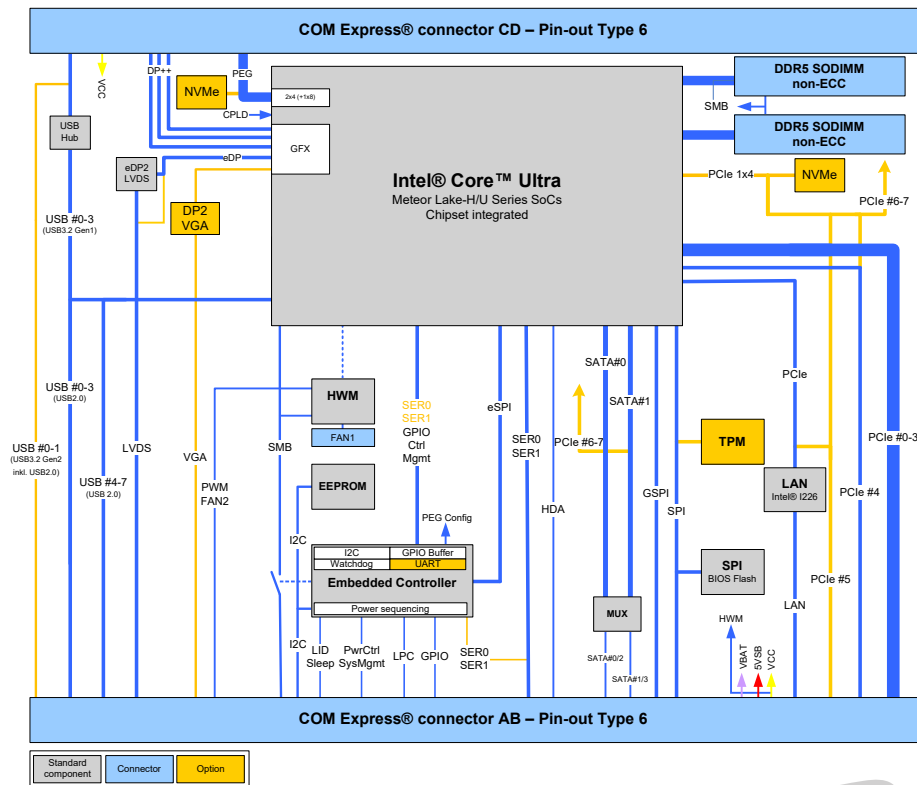

## CPU Variants

PRELIMINARY

	INTEL® CORE™ ULTRA METEOR LAKE H-SERIES (28W)	
CPU	Core™ Ultra 7-155H	Core™ Ultra i5-125H
CORES	16	14
NUMBER OF P-CORES	6	4
FREQUENCY BASE/TURBO (P-CORES)	1.4/4.8 GHz	1.2/4.5 GHz
NUMBER OF E-CORES	8	8
FREQUENCY BASE/TURBO (E-CORES)	0.9/3.8 GHz	0.7/3.6 GHz
NUMBER OF LPE-CORES	2	2
TDP	28/20 W	28/20 W
CACHE	24 MByte	18 MByte
IBECC	dependent on used OS	dependent on used OS
TCC/TSN	no	no
	INTEL® CORE™ ULTRA METEOR LAKE U-SERIES (15W)	
CPU	Core™ Ultra 7-155U	Core™ Ultra 5-125U
CORES	12	12
NUMBER OF P-CORES	2	2
FREQUENCY BASE/TURBO (P-CORES)	1.7/4.8 GHz	1.3/4.3 GHz
NUMBER OF E-CORES	8	8
FREQUENCY BASE/TURBO (E-CORES)	1.2/3.8 GHz	0.8/3.6 GHz
NUMBER OF LPE-CORES	2	2
TDP	15/12 W	15/12 W
CACHE	12 MByte	12 MByte
IBECC	dependent on used OS	dependent on used OS
TCC/TSN	no	no

PART NO.	CPU	PCH	MEMORY	MEM TYPE	FLASH	OP. TEMPERATURE
38042-0000-14-7	Ultra 7-155H	-	SO-DIMM	non-ECC	-	0 °C - 60 °C
38042-0000-12-5	Ultra 5-125H	-	SO-DIMM	non-ECC	-	0 °C - 60 °C
38042-0000-17-7	Ultra 7-155U	-	SO-DIMM	non-ECC	-	0 °C - 60 °C
38042-0000-13-5	Ultra 5-125U	-	SO-DIMM	non-ECC	-	0 °C - 60 °C

## Carrier

ARTICLE	PART NO.	DESCRIPTION
COME EVAL CARRIER2 T6	38116-0000-00-0	COM Express® Evaluation Carrier Type 6
COME EVAL CARRIER2 T6 5mm	38116-0000-00-5	COM Express® Evaluation Carrier Type 6 with 5 mm COMe connector

## Cooling

ARTICLE	PART NO.	DESCRIPTION
HSP COME-BMT6 CU-CORE THREADED	38042-0000-99-0	Heatspreader for COM-bMT6, Cu-core, threaded mounting holes
HSP COME-BMT6 CU-CORE THROUGH	38042-0000-99-1	Heatspreader for COM-bMT6, Cu-core, through mounting holes
HSK COME-BASIC ACTIVE (W/O HSP)	38025-0000-99-0C05	Active Cooler for COMe-bMT6/bRP6/bxL6/bV26/bDV7/blD7 to be mounted on HSP
HSK COME-BASIC PASSIVE (W/O HSP)	38025-0000-99-0C06	Passive Cooler for COMe-bxL6/bDV7 to be mounted on HSP

## Memory

PART NO.	MIN. SPEC.	SIZE	ECC	OP. TEMPERATURE
97040-4856-BRP6	DDR5-5600	48 GByte	no	0 °C - 60 °C
97040-3256-BRP6	DDR5-5600	32 GByte	no	0 °C - 60 °C
97040-1656-BRP6	DDR5-5600	16 GByte	no	0 °C - 60 °C
97040-0856-BRP6	DDR5-5600	8 GByte	no	0 °C - 60 °C

## Global Headquarters

Kontron Europe GmbH

Gutenbergstraße 2  
 85737 Ismaning, Germany  
 Tel.: + 49 821 4086-0  
 info@kontron.com

www.kontron.com